

INCREMENTAL WIRE TYPE ENCODER

HLS-S

FEATURES

- Output signal: square wave
- Measuring range: 200, 500, 1000 mm
- Pulse per resolution: 1 mm, 0.5 mm; 0.2mm; 0.1mm; 0.04mm
- CE approval

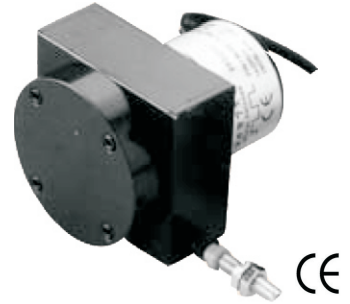

ORDER INFORMATION: HLS-S - [Code 1] - [Code 2] - [Code 3] - [Code 4] - [Code 5]

Code 1	Measuring Range	Code 2	Resolution	Code 3	Output Phase	Code 4	Output Waveform	Code 5	Aux. Power
02	200 mm	1	1 mm / pulse	Empty	AB Phase	Empty	Voltage	Empty	DC 8~26V
05	500 mm	0.5	0.5 mm / pulse	Z	ABZ Phase	C	Open Collector	5V	DC 5V
10	1000 mm	0.2	0.2 mm / pulse			P	Push-Pull		
		0.1	0.1 mm / pulse			L	Line-Driver 5Vdc		
		0.04	0.04 mm / pulse			HL	Line-Driver 8~26Vdc		

SPECIFICATION

- ◆ Detection System: Incremental
- ◆ Output Wave: Square wave
- ◆ Output Phase: AB phase or ABZ phase
- ◆ Output Capacity: 20 mA
- ◆ Temperature Coefficient: 100ppm / °C (0~60°C)
- ◆ Operating Temperature: 0~60°C
- ◆ Operating Humidity: 20~90% RH (non-condensing)
- ◆ Storage Temperature: -10~70°C
- ◆ Storage Humidity: 20~90% RH (non-condensing)
- ◆ Power Supply: DC 8~26V, DC 5V
- ◆ Current Consumption: <60mA
- ◆ Waveform Rise/Fall: 2 usec
- ◆ Max. Frequency: 10KHz~100KHz
- ◆ Wire Material: 0.6 mm SUS304 with Nylon coated
- ◆ Starting Torque: 1500~2000 g
- ◆ Max. Speed: 1000 mm/sec
- ◆ Vibration: 10g (10 ± 1500Hz)
- ◆ Polarity: Against reverse protection (not with 5V)
- ◆ Shock: 20g/11msec
- ◆ Cable Length: 100 cm
- ◆ Weight: <450 g

DIMENSION

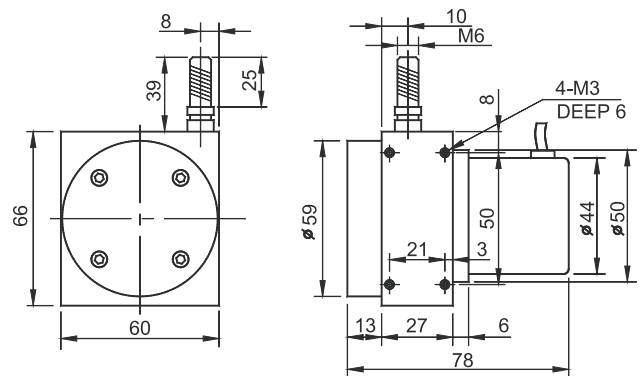

OUTPUT WAVEFORM

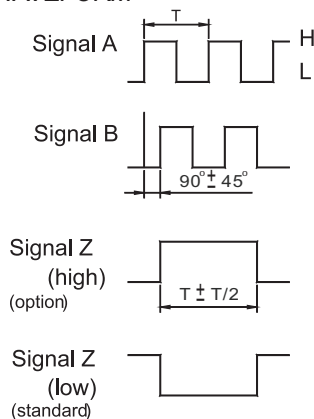

WIRING CONNECTION

