

5 DIGITAL MICRO-PROCESS METER with 5 ALARMS / SIMULATION OUTPUT

LM5

FEATURES

- Accuracy: $\pm 0.1\%$ F.S. ± 1 digit (DC / Potentiometer / Resistor / PT-100 / Load Cell)
 $\pm 0.2\%$ F.S. ± 1 digit (AC)
- Measuring AC, DC Voltage / AC, DC Current / Potentiometer / Resistor / PT-100 / Load Cell
- High brightness 0.8" LED display range: -19999~99999; decimal point selectable
- Max. Hold / Data Hold / Reset / 2~4 Alarms (Hi or Lo) programmable / Analog output (15 bit resolution) / RS-485 communication optional (The above options can exist together)
- Alarm 5 can be set for ERROR mode to detect the error of the meter
- Individual simulation analog output to check the sensors
- High stability, non-flammable case (PC), high safety
- CE approval



ORDER INFORMATION: LM5 - [Code 1] [Code 2] - [Code 3] - [Code 4]

Code 1	Input Type	Code 2	Voltage	Code 2	Current	Code 2	Potentiometer	Code 2	Resistor	Code 2	RTD (PT-100)	Code 2	Load Cell	Code 3	Aux. Power	Code 4	Analog Output
D	DC	V1	0~50mV	A1	0~20uA	P1	500Ω~10KΩ	I1	0~10Ω	T1	-50~50℃	L1	1mV/V EX.5V	A	AC/DC100~240V	N	None
A	AC AVG	V2	0~5V	A2	0~200uA	P2	10KΩ~100KΩ	I2	0~100Ω	T2	-100~100℃	L2	2mV/V EX.5V	B	DC 12V	A	4~20mA
M	AC TRMS	V3	1~5V	A3	0~2mA	P3	100KΩ~1MΩ	I3	0~1KΩ	T3	-200~200℃	L3	3mV/V EX.5V	C	DC 22~60V	V	0~10V
P	3 Wire Potentiometer	V4	0~10V	A4	0~20mA	PO	Option	I4	0~10KΩ	T4	0~600℃	L4	1mV/V EX.10V	D	DC 30~90V	O	Option
I	2 Wire Resistor	V5	0~36V	A5	0~200mA			I5	0~100KΩ	TO	Option	L5	2mV/V EX.10V				
T	RTD (PT-100)	V6	0~300V	A6	4~20mA			IO	Option			L6	3mV/V EX.10V				
L	Load Cell	V7	0~600V	A7	0~2A							LO	Option				
2	2, 3 Wire Sensor	VO	Option	A8	0~5A												
4	4 Wire Sensor			A9	0~10A												
				AO	Option												

- **1: 2 wire type offers excitation power DC24V for 2 wire (Loop Power) pressure, temperature, humidity sensors using.
 2: Please specify the input signal and display value, inquiry salespersons for special type.
 3: Load Cell type of excitation power DC5V can have 2 load cell in parallel; DC10V only can offer 1 load cell to use.

SPECIFICATION

- ◆ Accuracy: $\pm 0.1\%$ F.S. ± 1 digit (DC / Potentiometer / Resistor / PT-100 / Load Cell)
 $\pm 0.2\%$ F.S. ± 1 digit (AC)
- ◆ Display Screen: High brightness red LED; 20.3mm (0.8")
- ◆ Sampling Cycle: 16 cycles / sec (AVG=1)
- ◆ Display Range: -19999~99999
- ◆ Zero Adjustment: -19999~99999
- ◆ Over Range Indication: doFL / ioFL or -doFL / -ioFL
- ◆ Polarity Indication: Automatic with "-" indication
- ◆ Parameters Setting: Push buttons
- ◆ Back Up Memory: EEPROM
- ◆ Alarm Action: " \geq (Hi) on" or "< (Lo) on"
"(Error) on" (Alarm 5 only)
- ◆ Alarm Hysteresis Range: 0~9999
- ◆ Alarm Run Delay Time: 0~99 sec
- ◆ Relay Contact: AC 277V / 7A; DC 30V / 7A
- ◆ Analog Output Resolution: 15 bit
- ◆ Output Response Time: <250 msec (0~90%)
- ◆ Output Capability: Voltage Output: <20mA
Current Output: <10V
- ◆ Temperature Coefficient: 100ppm / °C (0~60°C)
- ◆ Operating Temperature: 0~60°C
- ◆ Operating Humidity: 20~90% RH (non-condensing)
- ◆ Storage Temperature: -10~70°C
- ◆ Storage Humidity: 20~90% RH (non-condensing)
- ◆ Power Supply: AC/DC 100~240V; DC 22~60V
- ◆ Power Consumption: 8.5VA (all functions output)
2KVac / 1min (Input / Power)
- ◆ Surge Test: Voltage: >2V for 20KΩ / V; $\leq 2V$ for >200MΩ
- ◆ Input Impedance: Current: $\geq 0.2A$ at 100mV; <0.2A at 1V
- ◆ Dimensions: 96(W)*48(H)*110(D) mm
- ◆ Weight: About 500 g

FRONT PANEL & KEY FUNCTIONS

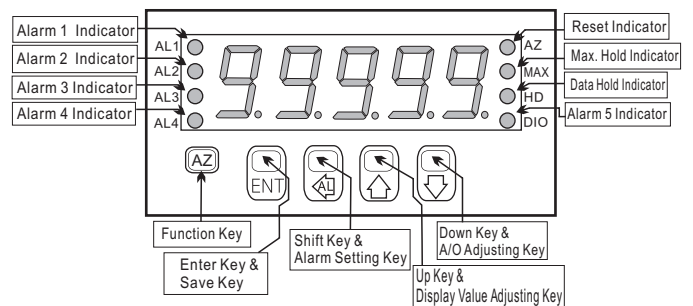

DIMENSION

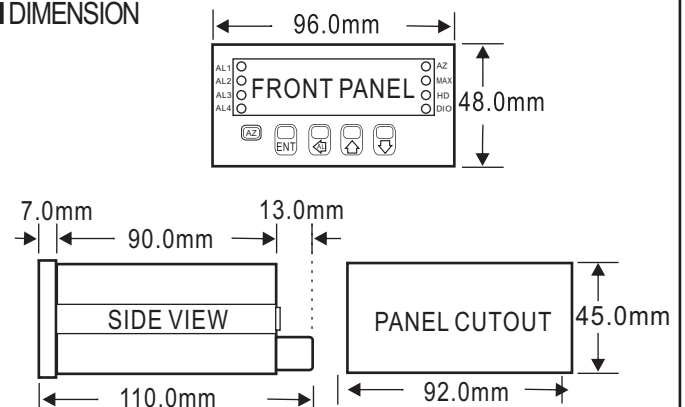

WIRING CONNECTION

● Voltage, Current (AC, DC)

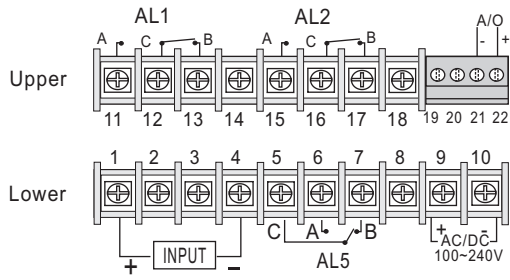

● Temperature (RTD)

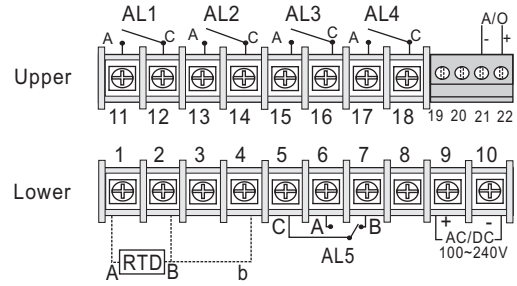

● 2 Wire Resistor

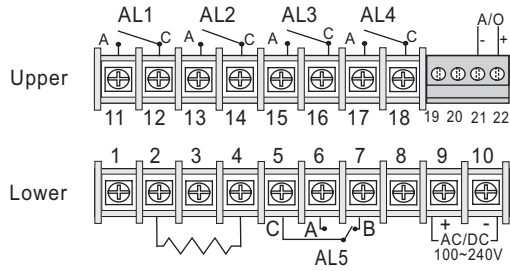

● 3 Wire Potentiometer

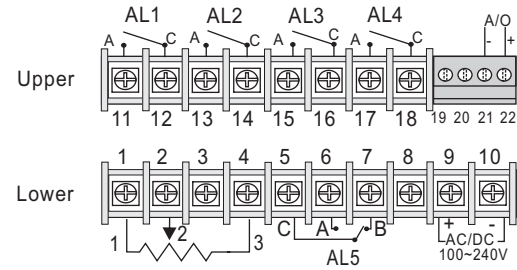

● 4 Wire Sensor or Load cell

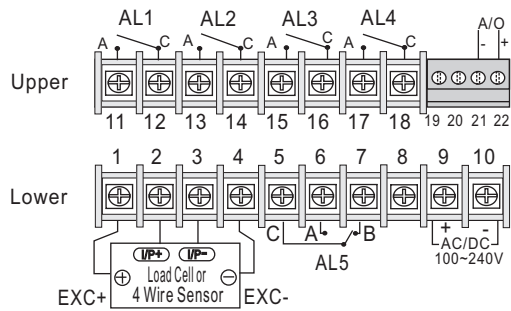

● 2,3 Wire Sensor

